

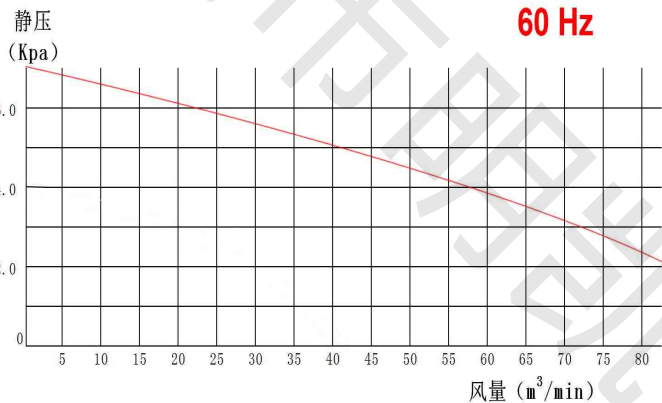

TB 200-20

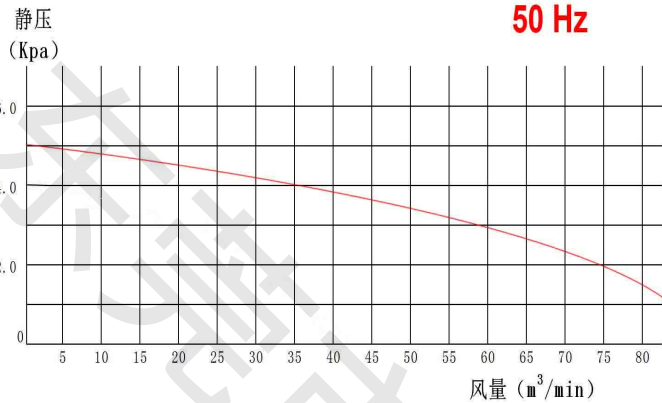

TB200-20

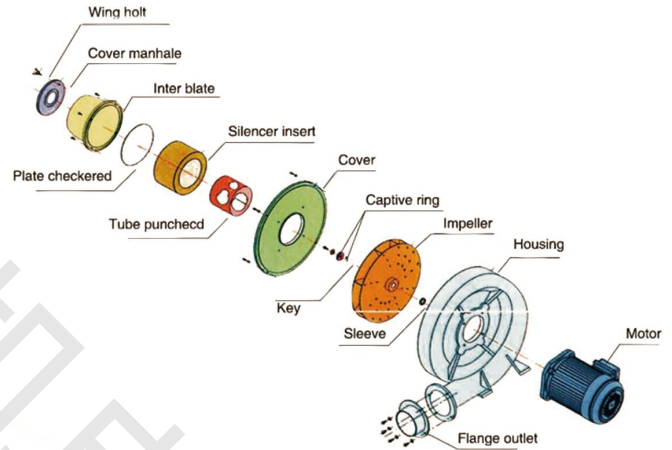
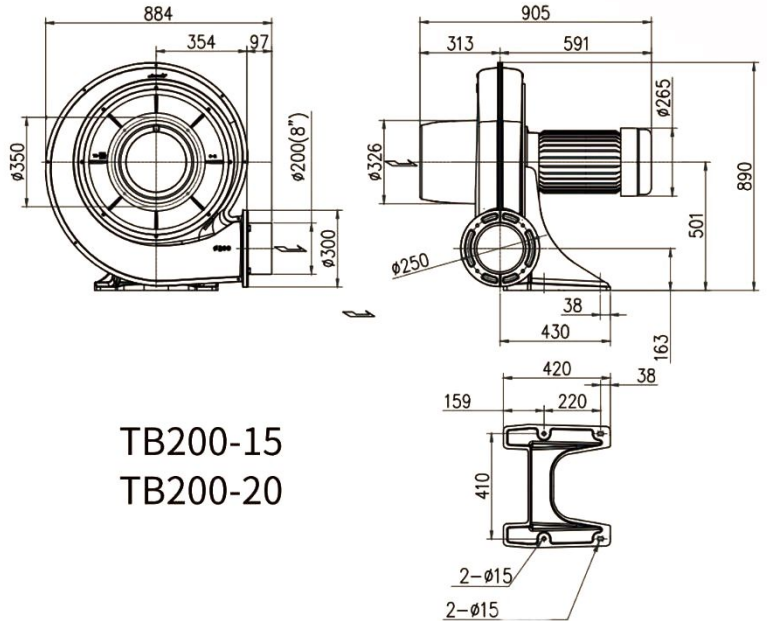

TB系列规格表

风机型号 Type	相数 Phase	功率 Power (KW)	额定电压 Voltage (V)	额定电流 Current (A)	最大静压 (吐出) Vacuum/Pressure (max) (KPa)	最大风量 (吐出) Air Flow (max) (m3/min)	出入口 口径 In/Out (mm)	噪音 Noise Level (dB)	重量 Weight (Kg)
TB100-1	1 ~	0.75	220	5	1.3/2.1	18/22	IN 200	70/80	21
	3 ~		220 / 380	3 / 2.0			OUT 100		
TB100-2	1 ~	1.5	220	9	2/3	20/25	IN 200	70/85	28
	3 ~		220 / 380	5.5 / 3.5			OUT 100		
TB125-3	3 ~	2.2	220 / 380	8/5	2.4/3.6	33 / 39	IN 252 OUT 125	80/90	37
TB150-5	3 ~	3.7	220 / 380	13/7.5	3.8/5.3	48/53	IN 252 OUT 150	90/95	52
TB150-7.5	3 ~	5.5	220 / 380	19/11.5	4/5.3	50/65	IN 252 OUT 150	90/95	73
TB150-10	3 ~	7.5	220 / 380	26/15.5	4/5.3	60/75	IN 252 OUT 150	90/95	82
TB150L-10	3 ~	7.5	220 / 380	26/18	5/6.5	40/53	IN 252 OUT 150	90/100	85
TB200-15	3 ~	11	220 / 380	36/22	5/6.5	65/85	IN 315	95/110	117
							OUT 200		
TB200-20	3 ~	15	220 / 380	47/28	5/7	90/100	IN 315 OUT 200	95/110	130

TB系列中压风机出风口可选360°八个方向，电机位置可选左右两个位置